

Installation Instructions

BMW X5 2007-13

Contents

Bumpers	4
Anti-abrasion pad	7
Mounting clips with hook	4
Mounting clips without hook	3
Pins	7
#6 x 5/8+Truss Head Screws	3
#6 x 5/8+Flat Head Screws	4
Nylon washers	3
±qBrackets	4
Hook brackets 20.5mm	1
Hook brackets 26.0mm	2

TOOLS REQUIRED

- Phillips Screwdriver
- Tape Measure

Illustration #1 – Clip and Bump Location

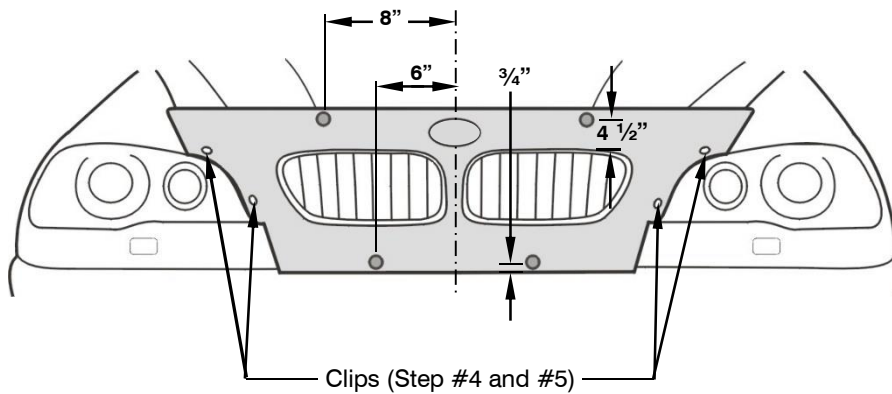
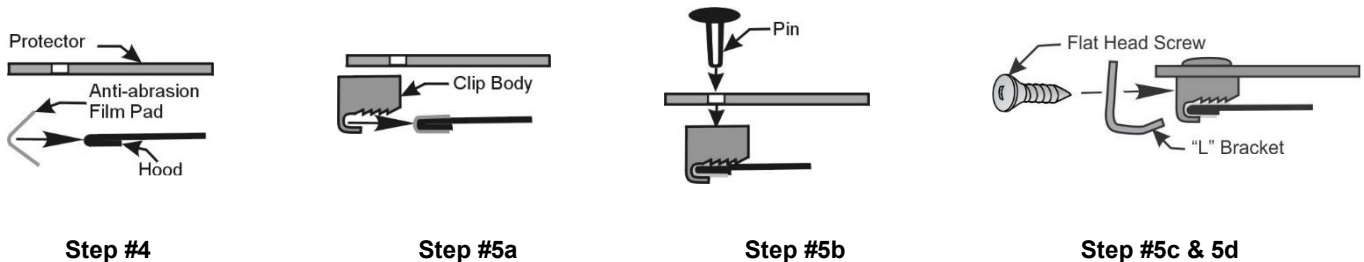

Illustration #2 – Clip with Hook



Step #4

Step #5a

Step #5b

Step #5c & 5d

Installation

1. Ensure the hood is clean and dry inside and out. Release the hood, but do not open it.
2. Install the bumpons as shown in *Illustration #1*. **Attention: The bumpons must be installed on the hood, not on the protector!!!** If the bumpons are installed on the protector, they will wear through the paint.
3. Center the protector on the hood, resting on the bumpons.
4. Peel and fold an anti-abrasion pad in half over the edge of the hood, underneath each of the four (4) upper holes in the protector located closest to the headlights. See *Illustration #1 and #2 – Step #4*.
5. a) Place a clip body with hook over each of the anti-abrasion film pads on the edge of the hood as shown above in *Illustration #2 – Step #5a*.
b) Insert a pin through the protector into each of the clip bodies. See *Illustration #2 – Step #5b*.
c) Insert a **#6 x 5/8"** flat head screw through an \perp q bracket and into each clip body. See *Illustration #2 – Step #5c & 5d*.
d) Make sure all the components are well seated together; the protector is centered on the hood, and then tighten the screws into the clip bodies.
6. Open the hood of the vehicle.
7. Peel and fold an anti-abrasion film pad in half over the edge of the hood, underneath each of the three (3) bottom holes in the protector. See *Illustration #3 – Step #7*
8. Starting with the one (1) center hole in the protector, place a clip body without hook between the hood and the protector and align with the hole; insert a pin through the protector into the clip body. See *Illustration #3 – Step #8*.
9. Place a nylon washer onto a **#6 x 5/8"** truss head screw; engage a **20.5mm** hook bracket on the edge of the hood, insert the screw through the hook bracket and into the clip body. Make sure all components are well seated together, and then tighten the screw into the clip body. See *Illustration #3 – Step #9*.
10. Repeat steps #8 and #9 for the remaining (2) outside holes using the **26.0mm** hook brackets.
11. On some vehicles it may be necessary to adjust the hood bumpers and/or latch for proper clearance.

Note: Do not pull on the protector when opening or closing the hood.

Illustration #3 – Hook Bracket Configuration

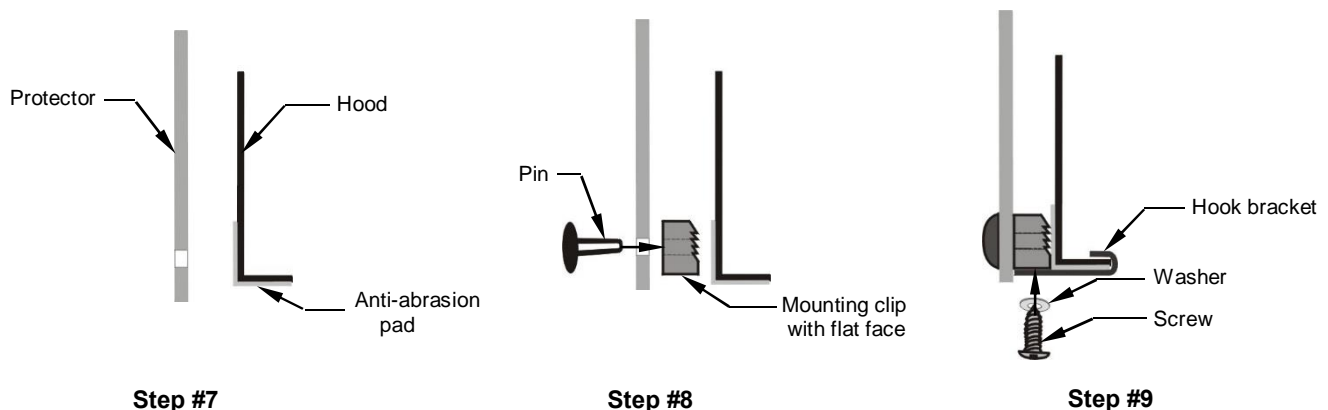

Hook Bracket Locations

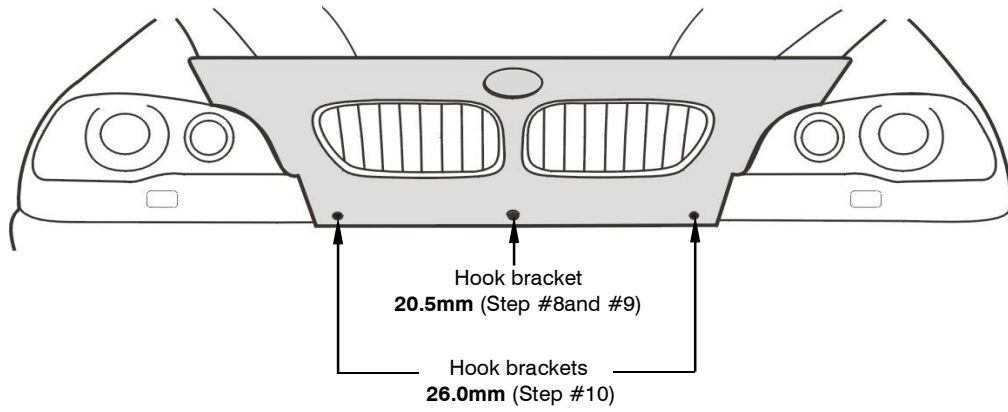

CARE INSTRUCTIONS

Clean the protector with a mild soap and water solution or plastic cleaner only. Do not use chemicals or solvents. Periodically check to make sure the bumpons are in place and the protector is secure. Avoid using automatic car washes. Do not pull on protector when opening or closing the hood.
